

COMUNE CHIARAVALLE

PROVINCIA DI ANCONA

PIANO DI RECUPERO

Ai sensi art. 27 della Legge 547/78

EDIFICI COLONICI VIA CAMPAGNA

PROPRIETA' : CANESTRARI - FABIETTI
FAVA - MEDICI- NICOLINI

PROGETTISTI : GEOM. PAOLO UGILI
ARCH. GIANNI RAFFAELI



CALCOLO SUL E VOLUMI

Data 30.06.2015

A large, stylized handwritten signature in black ink, written over a faint circular stamp or seal. The signature is fluid and cursive, extending across the right side of the page.

S.U.L. STATO ATTUALE

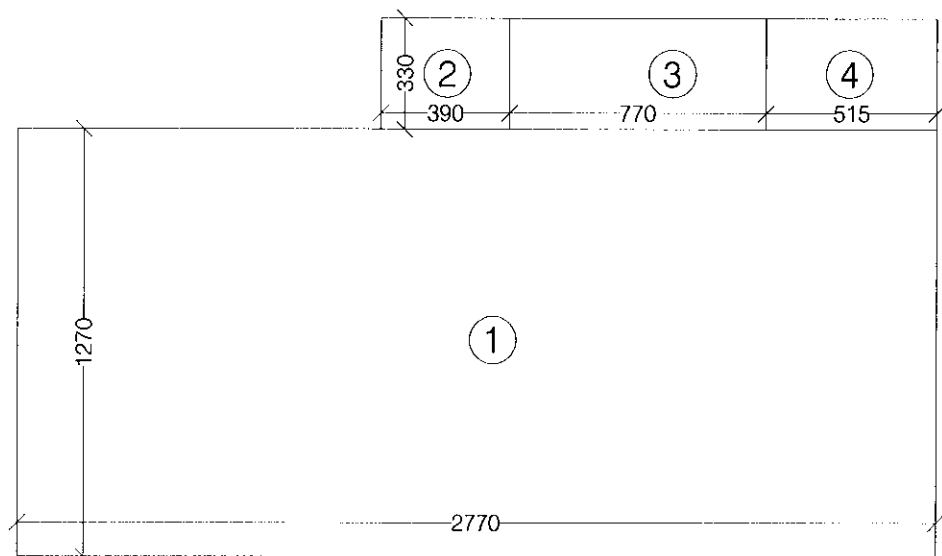

PIANO TERRA

1	27,70 m x 12,70 m =	mq 351,79
2	3,90 m x 3,30 m =	mq 12,87
3	7,70 m x 3,30 m =	mq 25,41
4	5,14 m x 3,30 m =	mq 16,96
Totale pt =		mq 407,03

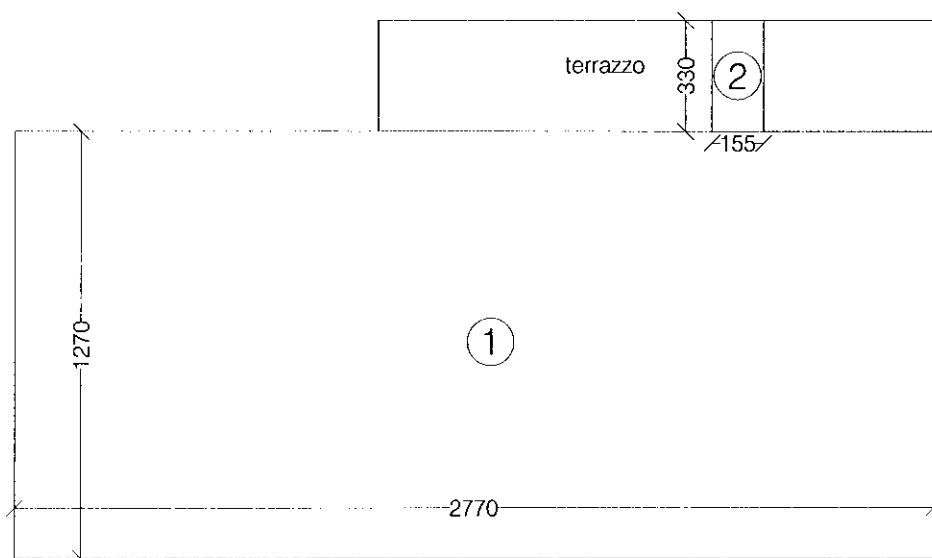

PIANO PRIMO

1	27,70 m x 12,70 m =	mq 351,79
2	1,55 m x 3,30 m =	mq 5,12
Totale p1 =		mq 356,91

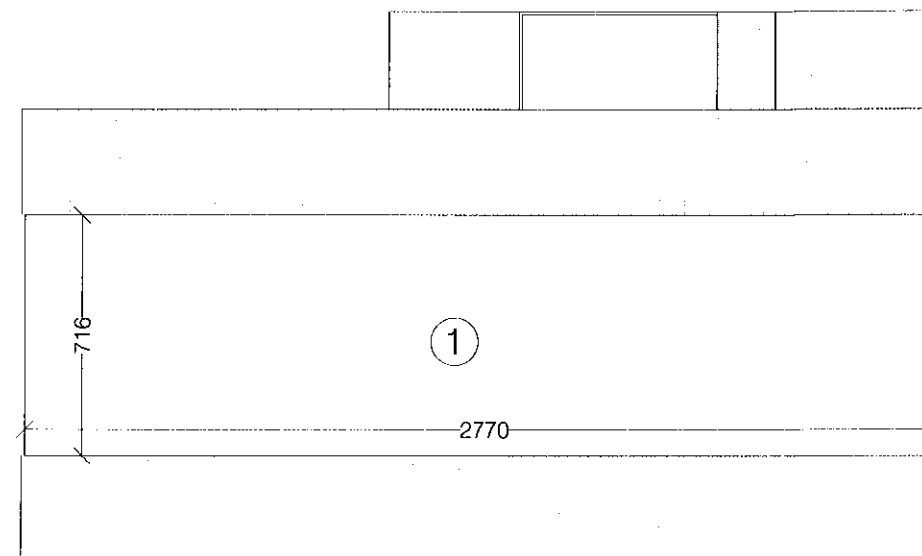

SOTTOTETTO

* nb: La superficie è stata considerata fino ad un' altezza utile interna di 1,50 m.

1	27,70 m x 7,15 m =	mq 198,05
Totale sottotetto =		mq 198,05

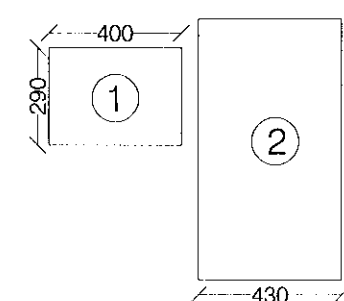

ACCESSORIO

1	2,90 m x 4,00 m =	mq 11,60
2	7,75 m x 4,30 m =	mq 33,33
Totale accessorio =		mq 44,93

S.U.L. - STATO ATTUALE

Piano terra =	mq 405,80
Piano primo =	mq 355,68
Sottotetto =	mq 198,26
Accessorio =	mq 44,93
TOTALE =	MQ 1004,67

S.U.L. STATO FUTURO

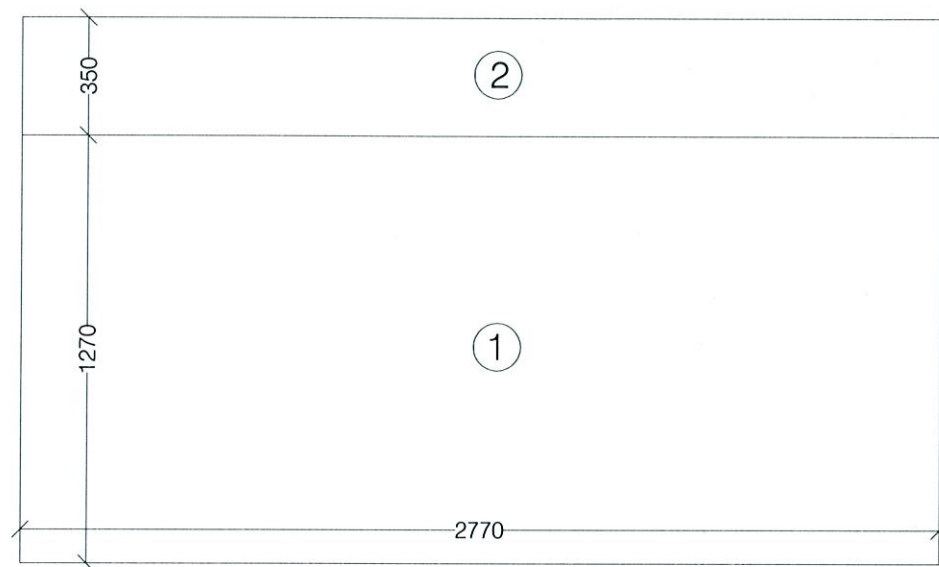

PIANO TERRA

1	27,70 m x 12,70 m =	mq 351,79
2	27,70 m x 3,50 m =	mq 96,95
Totale pt =		mq 448,74

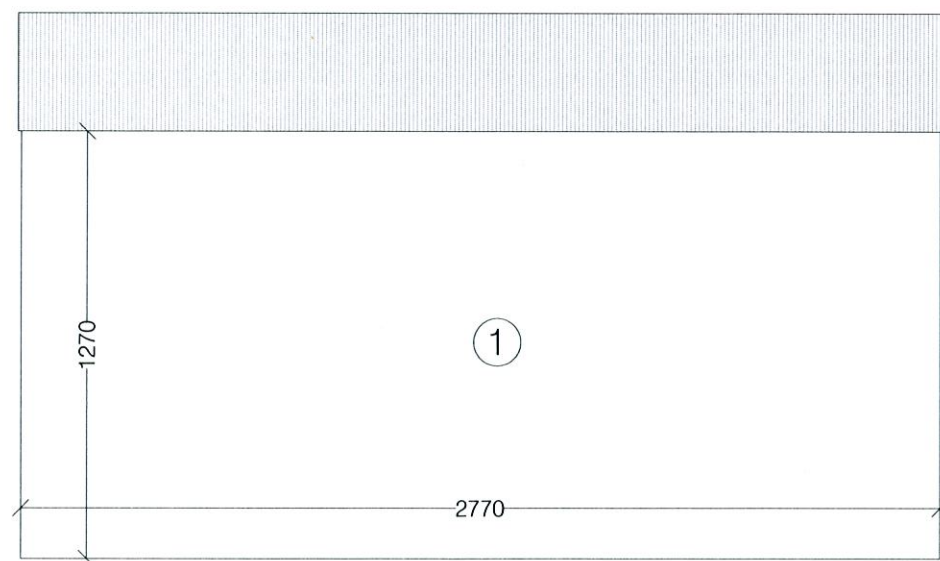

PIANO PRIMO

1	27,70 m x 12,70 m =	mq 351,79
Totale p1 =		mq 351,79

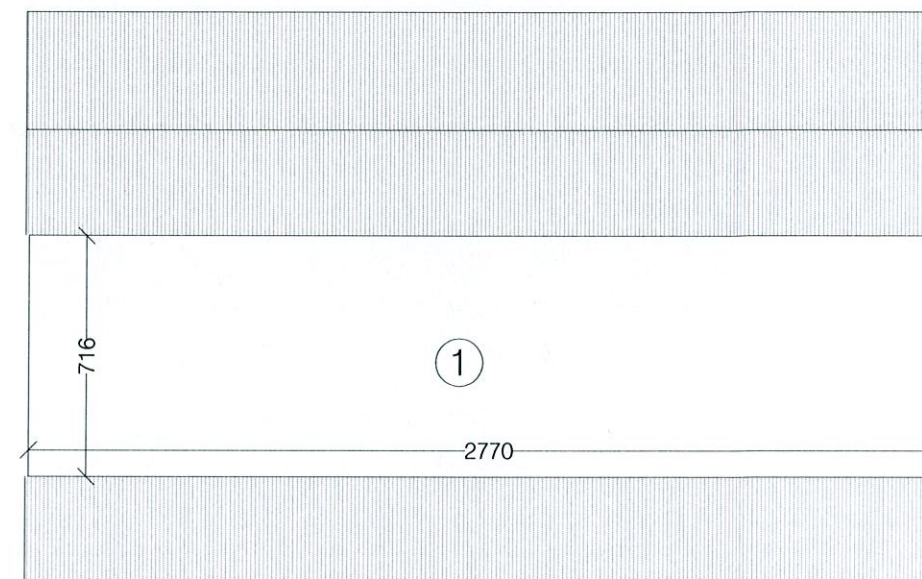

SOTTOTETTO

* nb: La superficie è stata considerata fino ad un' altezza utile interna di 1,50 m.

1	27,70 m x 7,15 m =	mq 198,05
Totale sottotetto =		mq 198,05

S.U.L. - STATO FUTURO	
Piano terra =	mq 448,74
Piano Primo =	mq 351,79
Sottotetto =	mq 198,05
TOTALE =	MQ 998,58

VOLUME STATO ATTUALE

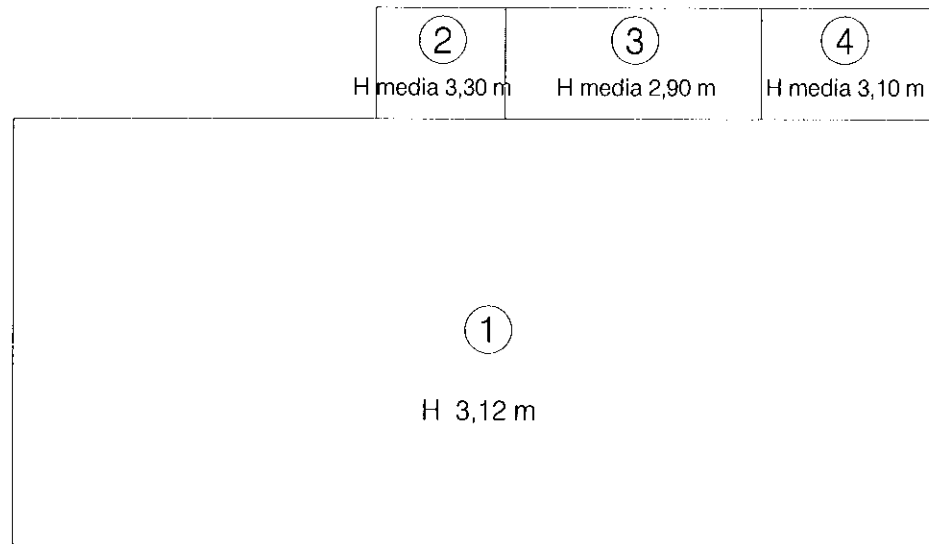

PIANO TERRA

1	351,79 mq x 3,12 m =	mc 1097,58
2	12,87 mq x 3,30 m =	mc 42,47
3	25,41 mq x 2,90 m =	mc 73,69
4	16,96 mq x 3,30 m =	mc 55,97
Totale pt =		mc 1269,71

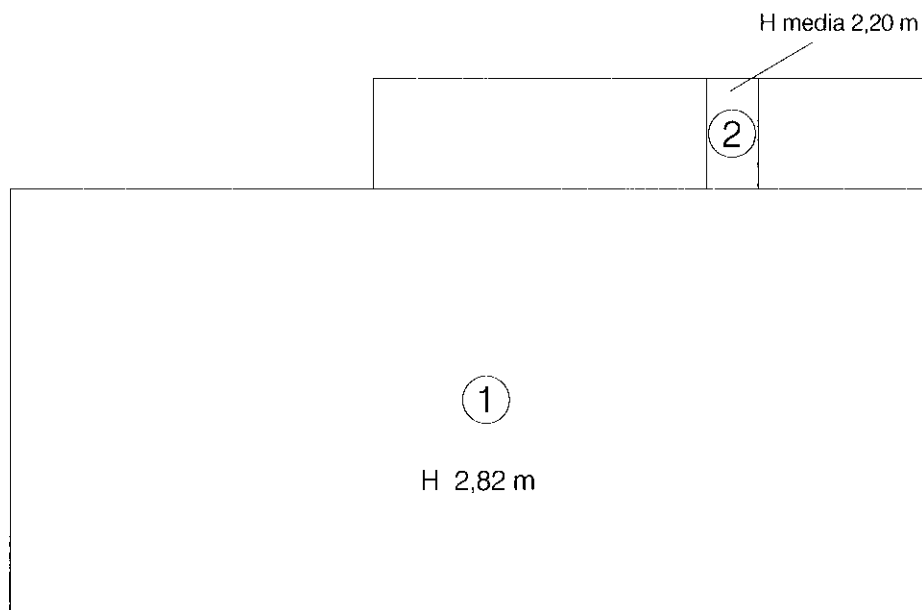

PIANO PRIMO

1	27,70 m x 12,70 m =	mq 351,79
2	1,55 m x 3,30 m =	mq 5,12
Totale p1 =		mq 356,91

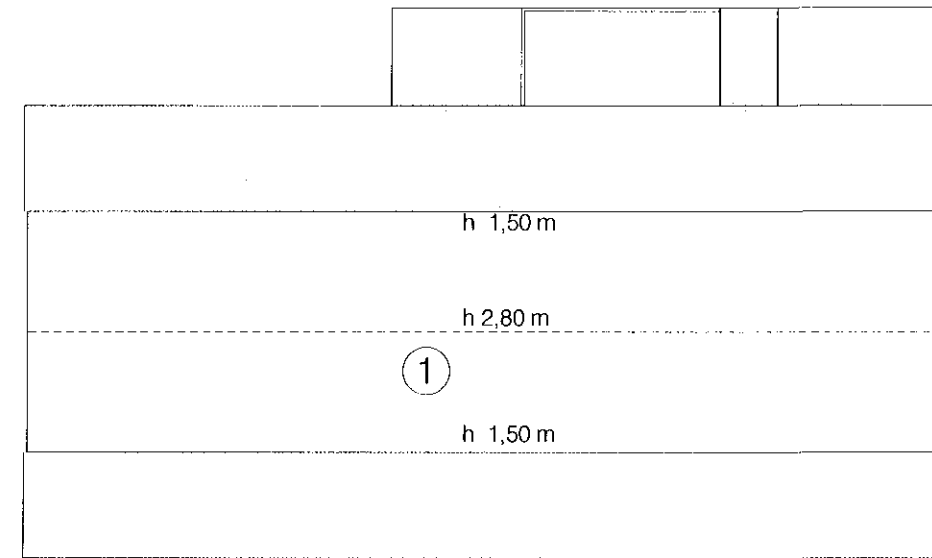

SOTTOTETTO

* nb: La superficie è stata considerata fino ad un' altezza utile interna di 1,50 m.

1	27,70 m x 7,15 m =	mq 198,05
Totale sottotetto =		mq 198,05

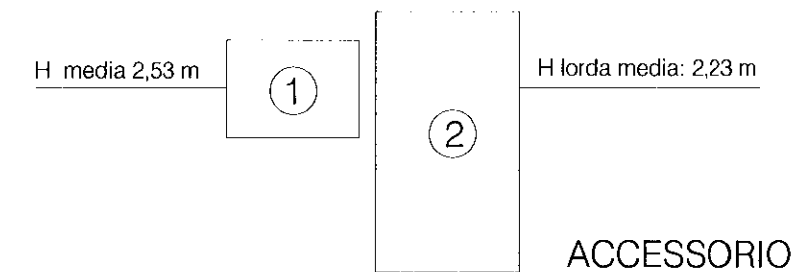

ACCESSORIO

1	2,90 m x 4,00 m =	mq 11,60
2	7,75 m x 4,30 m =	mq 33,33
Totale accessorio =		mq 44,93

VOLUME - STATO ATTUALE	
Piano terra =	mc 1269,71
Piano primo =	mc 1003,83
Sottotetto =	mc 425,81
Accessorio =	mc 107,01
TOTALE =	Mc 2806,36

VOLUME STATO FUTURO

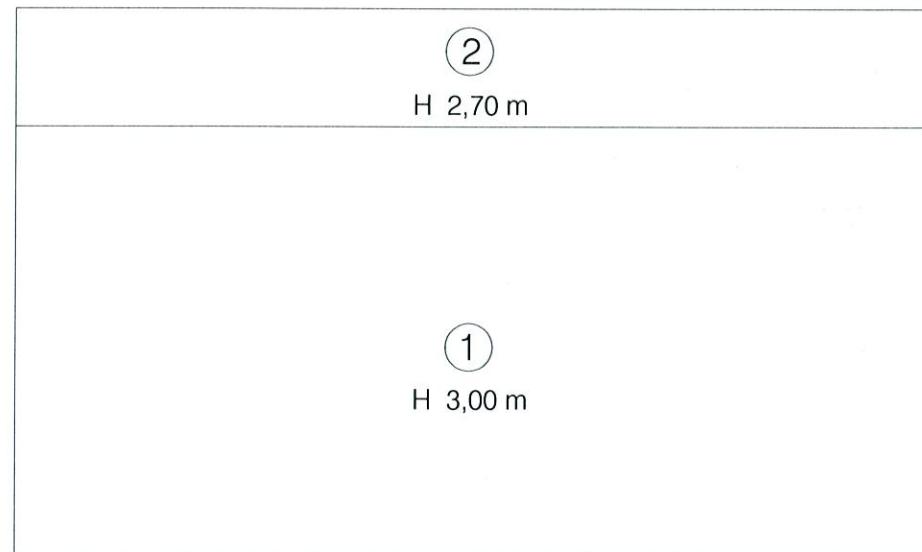

PIANO TERRA

1	351,79 mq x 3,00 m =	mc 1055,37
2	96,95 mq x 2,70 m =	mc 261,76
Totale pt =		mc 1317,13

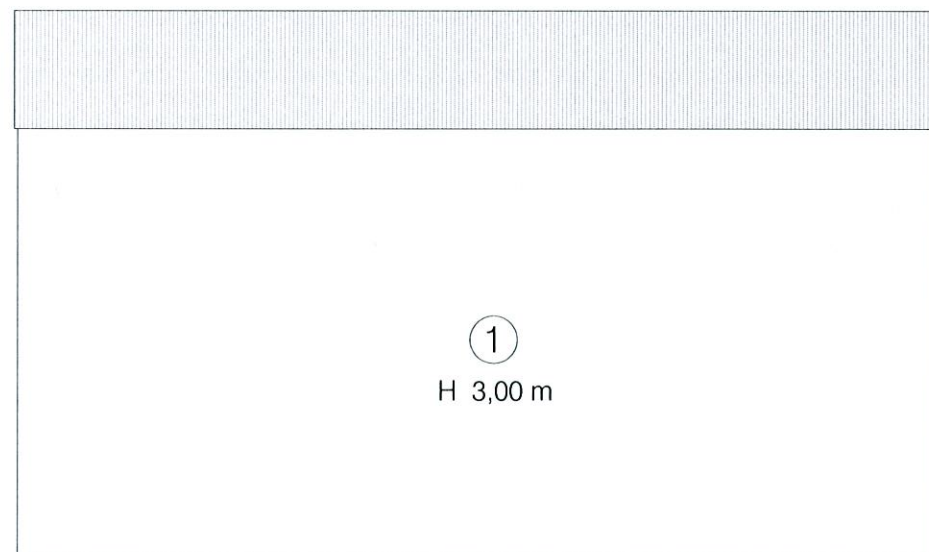

PIANO PRIMO

1	351,79 mq x 3,00 m =	mc 1055,37
Totale p1 =		mc 1055,37

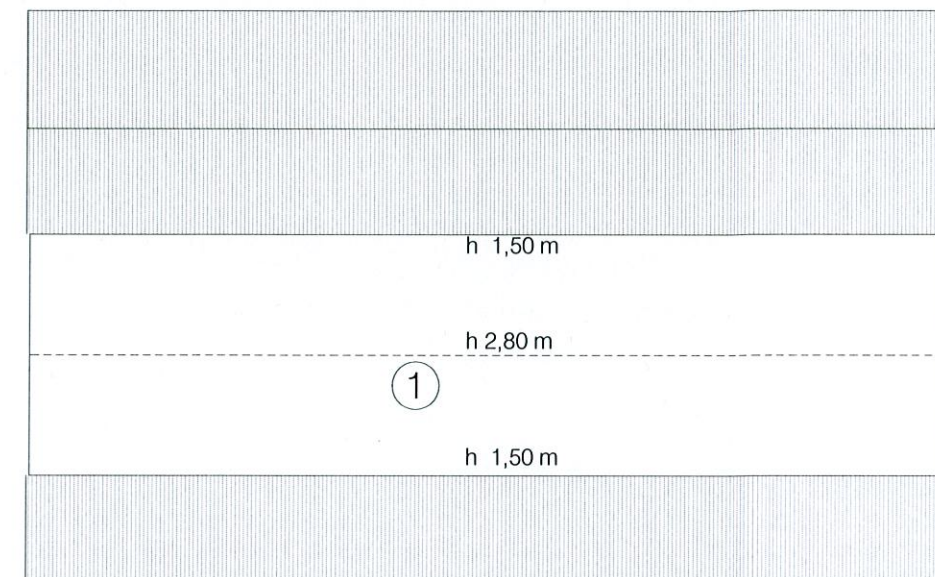

SOTTOTETTO

S.U.L. - STATO FUTURO	
Piano terra =	mq 448,74
Piano Primo =	mq 351,79
Sottotetto =	mq 198,05
TOTALE =	MQ 998,58

TABELLA RIEPILOGATIVA

S.U.L. - STATO ATTUALE	
Piano terra =	mq 405,80
Piano primo =	mq 355,68
Sottotetto =	mq 198,26
Accessorio =	mq 44,93
TOTALE =	MQ 1004,67

S.U.L. - STATO FUTURO	
Piano terra =	mq 448,74
Piano primo =	mq 351,79
Sottotetto =	mq 198,05
TOTALE =	MQ 998,58

VOLUME - STATO ATTUALE	
Piano terra =	mc 1269,71
Piano primo =	mc 1003,83
Sottotetto =	mc 425,81
Accessorio =	mc 107,01
TOTALE =	Mc 2806,36

VOLUME - STATO FUTURO	
Piano terra =	mc 1317,13
Piano primo =	mc 1055,37
Sottotetto =	mc 425,81
TOTALE =	Mc 2798,31